



Supplement of

British Antarctic Survey’s aerogeophysical data: releasing 25 years of airborne gravity, magnetic, and radar datasets over Antarctica

Alice C. Frémand, J. A. Bodart et al.

Correspondence to: Alice C. Frémand (almand@bas.ac.uk) and Julien A. Bodart (julien.bodart@ed.ac.uk)

The copyright of individual parts of the supplement might differ from the article licence.

Supplementary Information

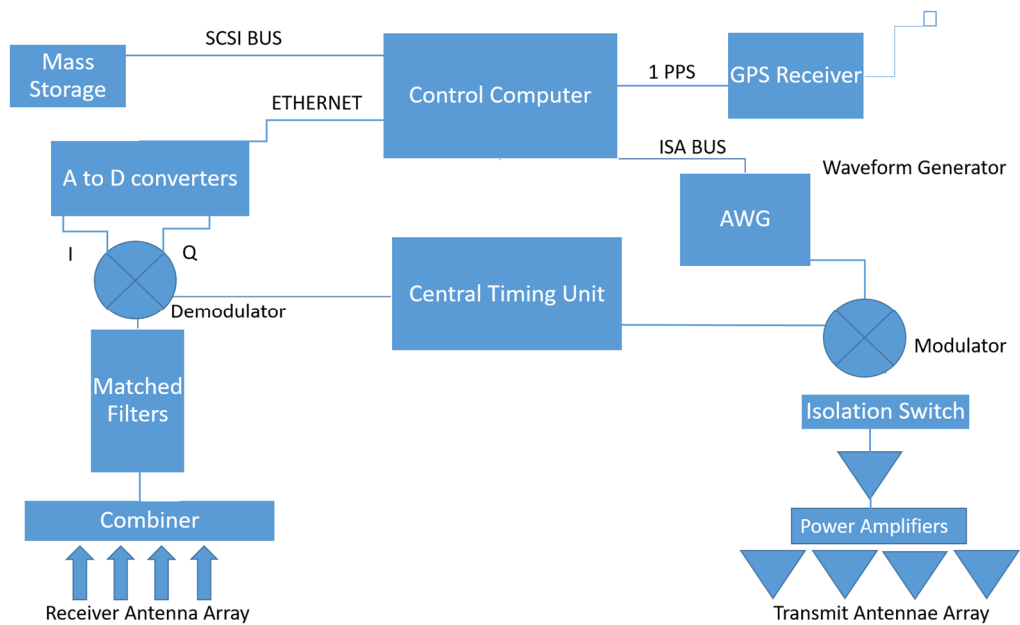

Figure S1. Digitised version of the diagram describing the set-up for the “BAS-built” radar system (Corr and Popple, 1994).

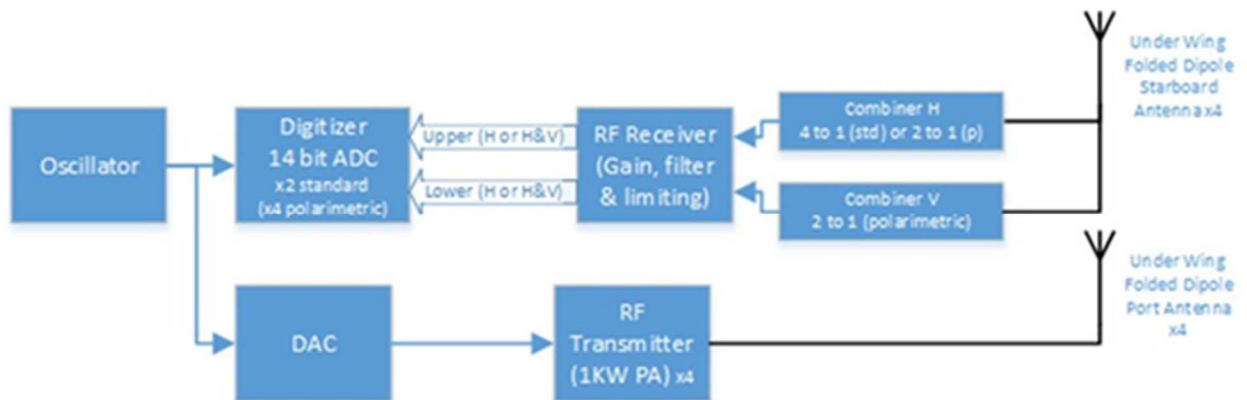

Figure S2. Diagram describing the set-up for the PASIN-1 radar system.

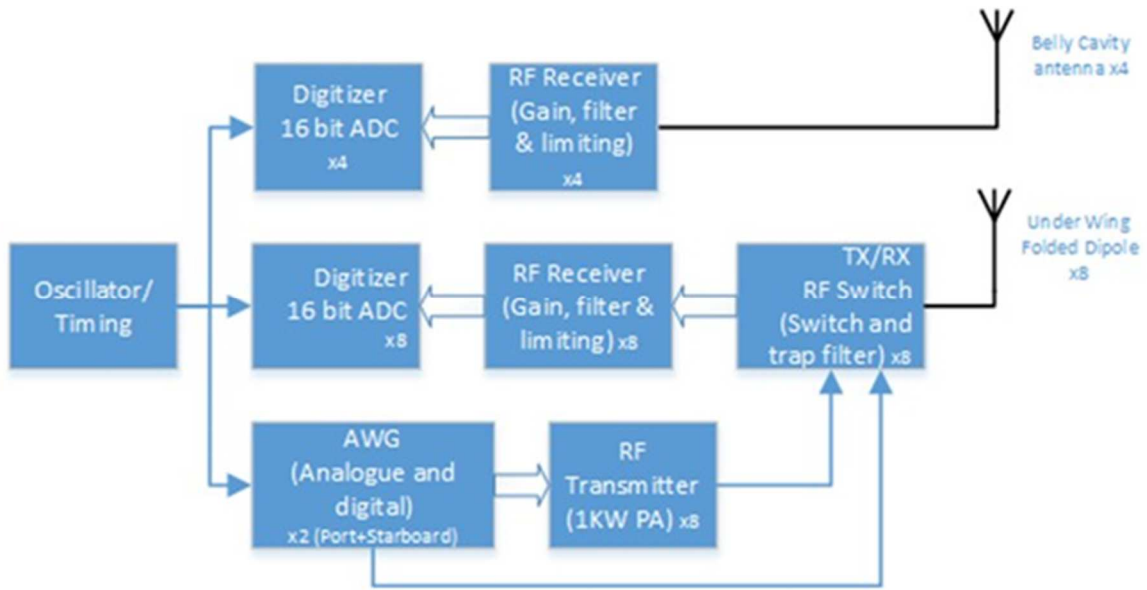

Figure S3. Diagram describing the set-up for the PASIN-2 radar system.

Table S1: PASIN-2 radar transmit (Tx) and receive (Rx) antennas description. “*” indicates Tukey-weighted.

| Waveform type (frame uS*) | Port | Starboard |
|---------------------------|---|---|
| 1. 0 to 64uS | Tx 4uS chirp*, Rx for remaining frame | Rx full frame |
| 2. 64uS to 128uS | Rx full frame | Tx 4uS chirp*, Rx for remaining frame |
| 3. 128uS to 192uS | Tx 4uS chirp* 180° out of phase with waveform 1, Rx for remaining frame | Rx full frame |
| 4. 192uS to 256 uS | Rx full frame | Tx 4uS chirp* 180° out of phase with waveform 2, Rx for remaining frame |
| 5. 256uS to 320 uS | Tx 1uS chirp* (15dB down), Rx for remaining frame | Rx full frame |